

Sk.Amjat (Managing Director)

+91 88885 85788

+91 9404467088

skskamjat@gmail.com

GST No. 27DCHPS5982M1ZL

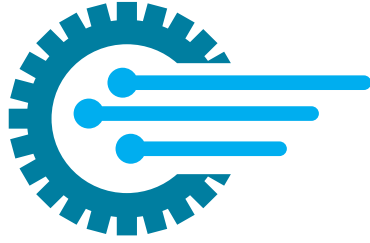

The Name Of Trust

Maharashtra

INDUSTRIES

Ginning & Pressing Automation Systems

Hot Box, Automatic R.C. Feeding System (Trolley) One by One
Lint Suction System, Super Cleaner, R.C. & Press Belt System,
Seed Screw Conveyor Ginning Pressing All Solution.

📍 Navsari Square, Walgaon Road, Amravati. 444601 (M.S.)

1) Sheet Conveyor

- a) Material :-
1.½ pipe
10 or 12 inch circle
40 mm HB hanger
1 inch rod.
- b) Driver System :- Motor with chain wheel pulley and 1 inch chain and sensor-less technology and heavy duty wiring.
- C) Transmission :- Crompton motor of 2HP

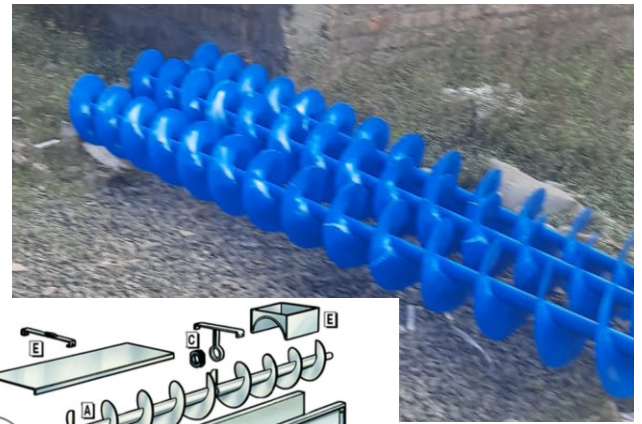
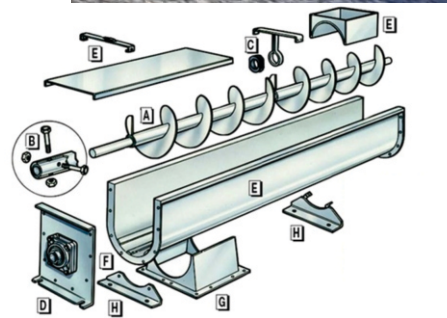

2) Overhead Sheet Dongey Conveyor

- a) Material :-
Dongey constructed in MS sheet of 16 gauge
1.½ inch c-class ISI mark pipe
10 or 12 inch circle
- b) Structure :-
40 mm HB hanger of 1 inch rod.
- c) Driver system :- Motor of 2HP or 3HP
Chain wheel pulley with 1 inch chain



3) Elevator

- a) Structure :-
MS angle of 50 x 50 x 5 inch &
18 gauge sheet
578 internal chain, 5 x 8 bowl
511 pedestal bearing
- b) Driver System :-
Motor
Pulley
Chain sprocket
1 inch chain
- C) Transmission :- Crompton motor of 3HP



4) Raw Cotton Trolley System

- a) Material :- Heavy wheel with 50mm shaft
4 inch roll
14 inch gauge sheet
- b) Structure :- Square pipe (5 x 5 inch)
Heavy channel (2 x 2 x 4 inch)
- c) Automotion unit :- Fully automatic panel with stop-less and sensor-less technology and heavy duty wiring.
- d) Transmission :- Crompton motor (3 Nos. of 2HP each)



5) Raw Cotton Hopper Box (1400mm x 40 Feet)

- a) Material :- MS sheet of 14 gauge
Angle (50 x 50 x 5)
C Channel (2 x 2 x 4)
- b) Structure :- Main roll of 10 inch
Heavy steel + Mini Kodi cleaner
Heavy duty belt (8mm, 3 ply)
C-class pulley & C class belt
- c) Panel :-
- d) Ideal roll at 12 inch distance



6) Conveyor Belt

- a) Structure :- MS sheet of 16 gauge and angle of 35 x 35 x 5 inch
Body angle (50 x 50 x 5 inch) + MS Sheet
Heavy duty belt (3ply, 8mm)
- b) Driver System :- Motor
Pulley
Chain sprocket
1 inch chain
- C) Transmission :- Crompton motor Depending upon length)



7) One by one lint system

- a) Material :- Pipe Hopper
60 no. glavanized sheet
- b) Unit :- MS ring, Separator, Bucket sacklon
Blower, Crompton motor
- c) Cromatic cylinder + Compresor
- d) Automation unit :-
PLC panel programs



8) Super Cleaner

- a) Structure :- Heavy duty super stick holl
Moving pulley of 10 inches
- b) Best quality bint of 1200 mm + 1400 mm + 1800 mm
- c) Crompton motor pulley with V-belt



9) Kawdi Cleaner

- a) 15 x 3 Feet long with 4 slots viz
 - i) Bhati
 - ii) Sarki (Halm)
 - iii) Nakki
 - iv) Kodi
- b) Weight :- 1000kg or 1250 kg
- c) 50 x 50 x 5 angle and MS sheet of 20 gauge size
- d) Transmission :- Motor drive wheel system

